

# 12 SB 200 (12V 200Ah)

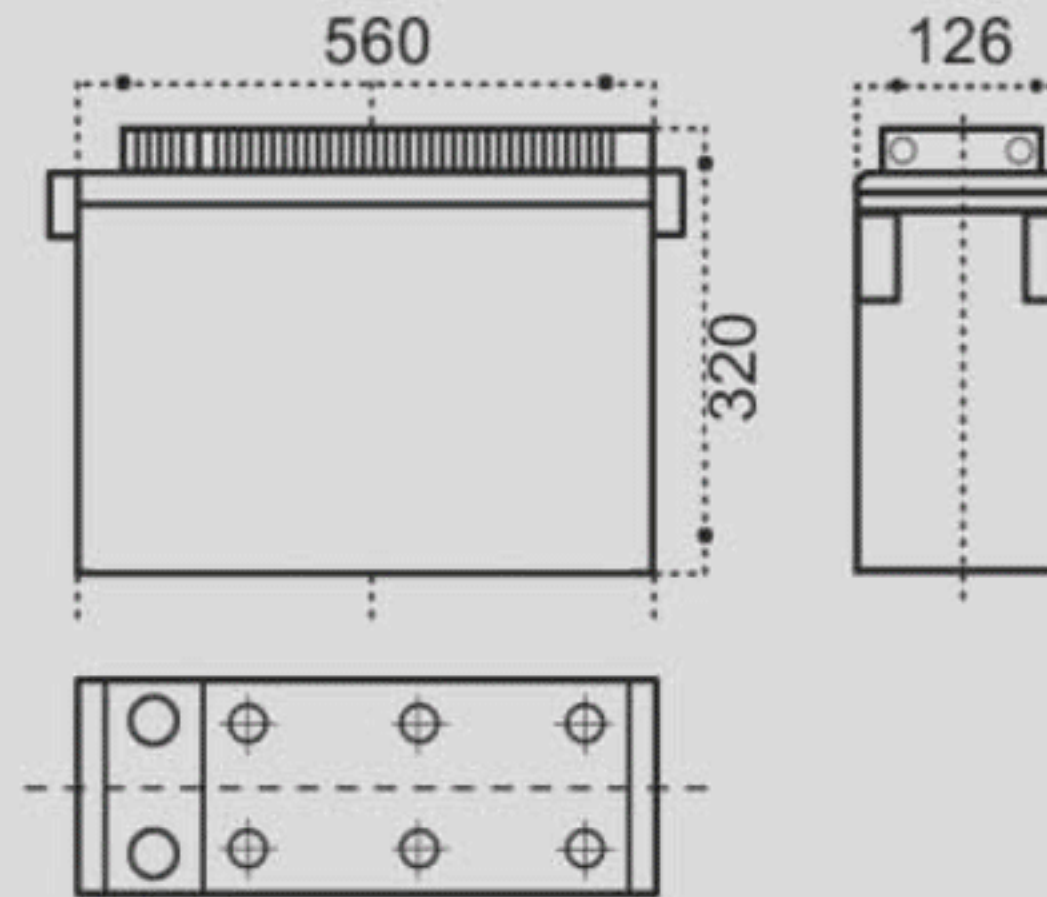

## Outer Dimensions (mm)



## Terminal Type (mm)

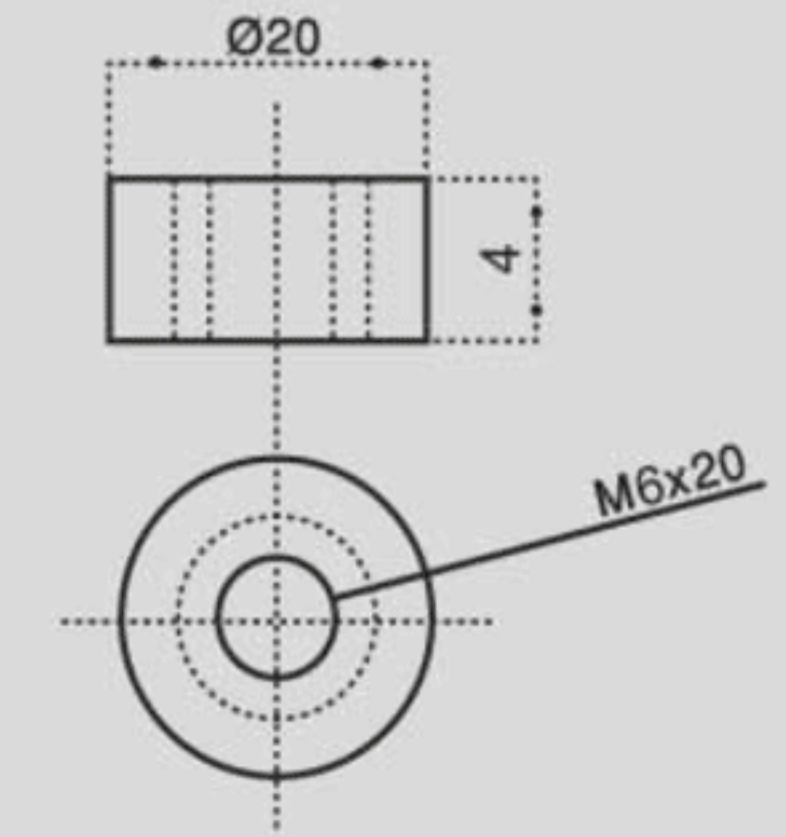

## Specifications

Nominal Voltage		12 V
Rated Capacity ( 10 Hour Rate )		200 Ah
Dimensions	Total Height	320 mm
	Height	320 mm
	Length	560 mm
	Width	126 mm
Container Material		ABS (UL94-HB/V0)
Weight Approx (±2.5%)		64 Kg

## Characteristics

Capacity 25°C (77°F)	10 hour-rate 3 hour-rate 1 hour-rate	200 Ah 142.5 Ah 106.1 Ah
Internal Resistance	Full Charge Battery at 25°C (77°F)	4.5 mΩ
Capacity Affected by Temperature (10 Hour Rate)	35°C 25°C 0°C -10°C	202 Ah 200 Ah 168 Ah 148 Ah
Self-Discharge at 25°C (77°F)	Capacity After The 3 Month of Storage Capacity After The 6 Month of Storage Capacity After The 12 Month of Storage	91 % 82 % 64 %
Charge Constant Voltage	Cycle	Voltage 2.40-2.45 / Cell
	Float	Voltage 2.23-2.25 / Cell

## Discharge Curves 25°C (77°F)

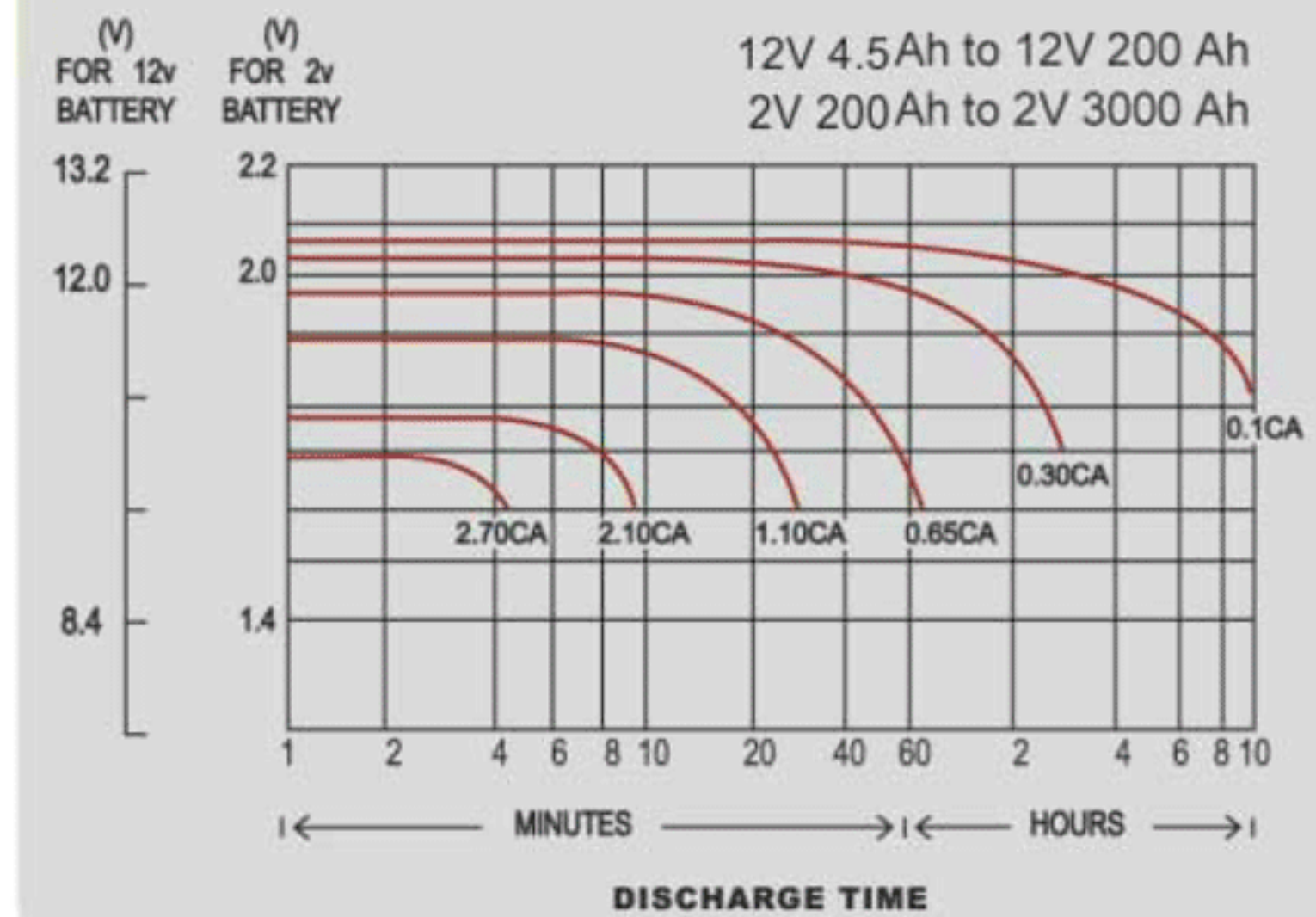

## Discharge and Final Voltage Table According to IEC60886-21 Standard

Discharge time	0.25 h	1 h	3 h	5 h	8 h	10 h
Final voltage	1.60 VPC	1.60 VPC	1.70 VPC	1.73 VPC	1.75 VPC	1.80 VPC

## Constant Current (A) Discharge Table at 25°C (77°F)

Amount of Current (A)	Discharge Time						
	1 h	2 h	3 h	5 h	8 h	10 h	20 h
	106.1	63.8	47.5	32.3	23	20	10.1